



# CORPORATE PROFILE



**Model Infra Corporation Pvt Ltd.**



**MODEL INFRA CORPORATAION PVT LTD**

**Reg. Off: No 6, SMK Chambers, 2<sup>nd</sup> floor  
1<sup>st</sup> 'A' main road, Sector A, Yelahanka New Town,  
Bangalore – 560064.  
Ph: +91 8956958105  
[www.modelinfra.com](http://www.modelinfra.com)**



Model Infra Corporation Pvt. Ltd.

## CONTENTS

1. **Who we are**
2. Who we work with
3. What we do
4. Products Profile
5. Awards & Certifications





## AN INTRODUCTION TO MIC

- ❖ **Over 25 Years of serving the biggest names in Construction Equipment, Mining, Energy, Agriculture, Exports, Defense, Railways and others.**
- ❖ **8 Strategically located Manufacturing plants in India.**
- ❖ **60,000+ MT per annum of Fabrication capacity.**
- ❖ **1,500+ Trained associates including certified Welders, Production, Design & Development, Quality, HR and Procurement Professionals.**
- ❖ **Professional Board and Management Team comprised of experienced Operational & Investor members.**
- ❖ **Proven track record of on time Delivery & Quality among all clients.**



# MANUFACTURING FACILITIES



**Bangalore,  
7,500 MTPA**



**Goa  
7,500 MTPA**



**Dharwad - Unit 1  
5,000 MTPA**



**Dharwad - Unit 2  
7,500 MTPA**



**Pune - Chakan  
10,000 MTPA**



**Pune - Alandi  
10,000 MTPA**



**Chennai - Pollivakkam  
10,000 MTPA**



**Chennai - Kandamglm  
5,000 MTPA**



**THROUGH OUR MANUFACTURING FACILITIES LOCATED AT STRATEGIC LOCATIONS,  
WE ADD VALUE TO OUR CLIENTS.**

-  Manufacturing facilities
-  Registered office

**Pune**

- 1. Unit 1 - Chakan
- 2. Unit 2 - Alandi

**Goa**

**Bangalore**

- Unit - Doddaballapura
-  Registered Office

**Dharwad 1 & 2 –  
Belur Industrial Area**

**Chennai**

- 1. Unit 1 - Pollivakkam
- 2. Unit 2 - Kandamangalam

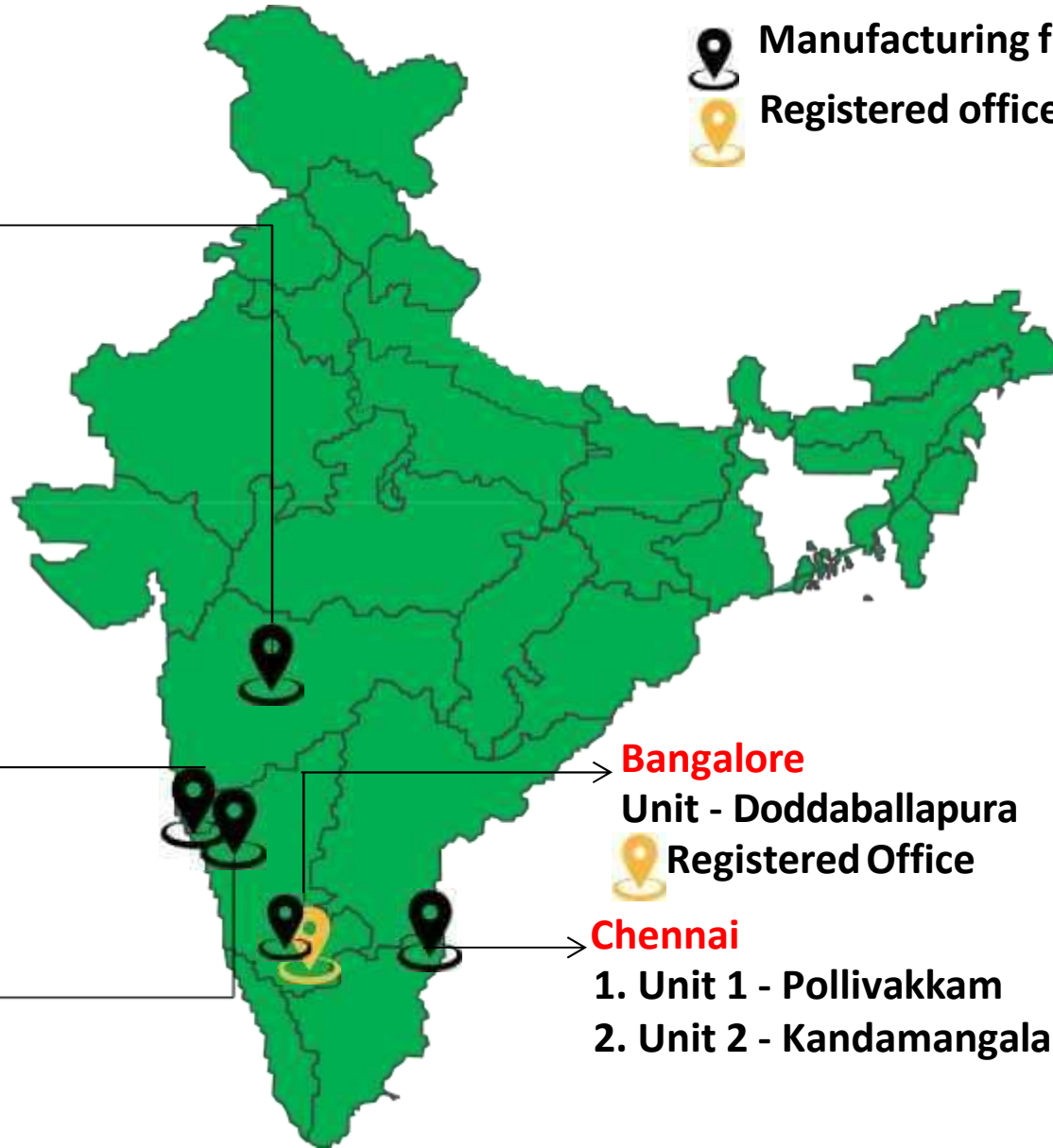



# EXECUTIVE MANAGENT TEAM

<b>Mr. K.P. Shivaprakash</b> Managing Director & CEO	Mr. K.P. Shivaprakash is a graduate Engineer & MBA with over 30 years of relevant experience. Prior to Joining MIC he had held Senior position as Director Operations for 10 years and had worked with Tier 1 suppliers of most of major OEMs in India in Auto, Construction and Agriculture space.
<b>Mr. Mahendranath Reddy</b> CFO and Director	Mr. Mahendranath Reddy is a CA and with over 25 years of experience in Finance, Accounts, Audit and Taxations . Prior to joining MIC he has worked at senior positions in companies such as BPL Ltd, Sindhu Cargo Service, Bharat Tissus etc. His areas of expertise include Banking, Finance and accounts, Fund raising and Company law compliance.
<b>Mr. Ganesh Ishwar</b> Director - Operations & Exports (Goa & Dharwad)	Mr. Ishwar is a graduate Engineer and MBA, he has been with MIC since its inception as a key founding member. Presently he is holding the key position of Director (Operations & Exports) and has exposure to strategic customer origination, business ramp up production engineering, new projects and planning.
<b>Mr. Robert Monis</b> Director & Corporate Head - HR	Mr. Robert Monis is graduated in law and completed his Post Graduate degree in Human Resources. He has over 25 years of experience in spans Law, Human Resources, Industrial Relations, Strategic Management and Corporate Affairs. Before joining MIC he held senior managerial positions at companies such as Forbes Gokak (a TATA group company), HFM Hammerle Astria, Oswal group and Fouress Engineering India Pvt Ltd.
<b>Mr. K Achuthan</b> Sr. Vice President - Operations (Bangalore)	Mr. Achuthan has over 25 years of rich and relevant experience in the domain areas of Quality Assurance & Compliance, Product & process Development and Manufacturing. He has worked with companies like Simpson, Usha Telehoist, Ajax- Fiori , Leeboy India & Surin Automotive in various capacities before MIC.
<b>Mr. Sanjay Patil</b> Director – Operations (Pune)	Mr. Sanjay Patil has about 25+ years of rich and relevant experience in the domain areas of Operations, product Development, Costing, projects & Marketing. He had worked with world class companies like Fleet Guard (Cummins group), Warade Group & Surin Automotive in various capacities before MIC.
<b>Mr. Nani Gopal Samal</b> Sr. Vice President - Operations (Chennai)	Mr. Nani Gopal Samal has over 25 years of rich and relevant experience in the domain areas of Quality Assurance & Compliance, Product & process Development and Manufacturing. He has worked with companies like Caparo Maruti, Mahendra UGINE & Surin Automotive in various capacities before MIC.



Model Infra Corporation Pvt. Ltd.

## CONTENTS

1. Who we are
2. Who we work with
3. What we do
4. Products Profile
5. Awards & Certifications





# VARIOUS SECTORS SERVED BY MIC

**Construction & Mining Eqpt**



**Energy**



**Railways**



**Defense**



**Agriculture**



**Material Handling**



**Exports**



**Aviation**







# OUR ESTEEMED CLIENTS



TATA HITACHI

Reliable solutions



VOLVO



TATA ADVANCED SYSTEMS



ALSTOM





Model Infra Corporation Pvt. Ltd.

## CONTENTS

1. Who we are
2. Who we work with
3. **What we do**
4. Products Profile
5. Awards & Certifications





# OUR CAPABILITIES

Design & Engineering

First Operations

Welding

Machining

Finishing

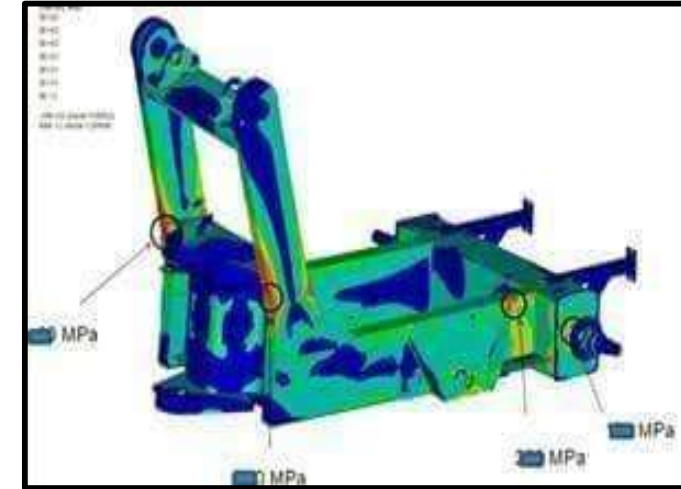
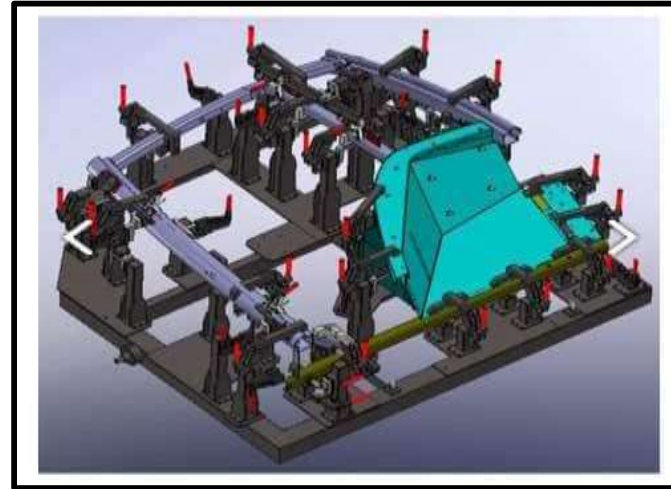
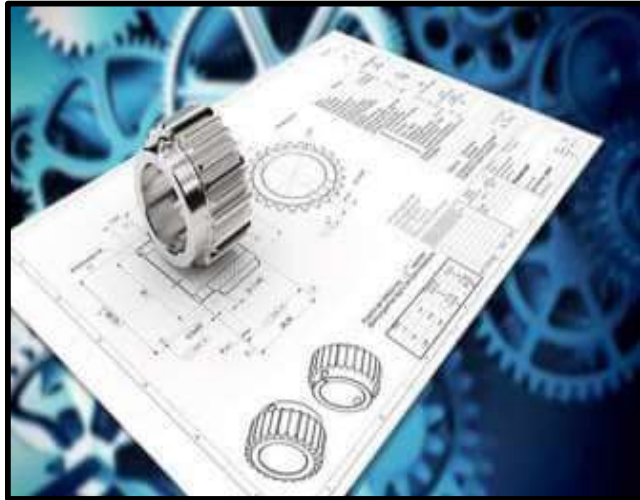

## Design Engineering

MIC's design engineers enable us to assist customers in the design and development of new products, optimization of clients designs, Assist with customization of products for domestic market.

## Production Engineering

Our production engineers enable us to develop fixtures and tools, optimize production process and minimize wastage. We have resources Specialized in Nesting, SPC, SQC, Lean, KAIZEN etc.,

## Design & PD - IT Resources

MIC has resources and capability in efficient utilization of following

Software / Packages:

- CREO parametric
- SOLID WORKS
  - ANSYS
  - ZW CAD
- SIGMA NEST



# OUR CAPABILITIES

Design & Engineering

**First Operations**

Welding

Machining

Finishing



## Plasma and Oxy Acetylene CNC Cutting Machines

Make: Messer

Numbers: 10

Length: 16000mm

Width: 6500mm

Total Capacity: 75000+ tons / month

## Laser Cutting Machines

Make: Messer, Trumpf  
(Omini Mat Fiber - 2000w)

Numbers: 3

Length: 12000mm

Width: 4000mm

Working Range: 3000 x 10000mm

## Robotic Beveling Machine

Make: IGM Austria

Numbers: 1

Number of Axes: 6

Working Radius: 3000mm

Angle of Rotation: 270°



# OUR CAPABILITIES

Design & Engineering

**First Operations**

Welding

Machining

Finishing



## CNC Press Brake

Make: YEWAI,  
Hindustan Hydraulics

Numbers: 6

Capacity: 450MT to 650MT

Stroke Length: 320mm to 400mm

Max Length / Thick : 6.5Mtr / 16mm

## CNC Rolling Machines

Make: DAVI Italy

Numbers: 5

Max Rolling Thickness: 19mm for  
3,000mm

With Cone rolling attachment

## RM Shot blasting

Make: Indabator

Numbers: 1

Feed Rate: 1 m/min

Eff. Blasting Size:  
8,000mm X 2550mm X 100mm



# OUR CAPABILITIES

Design & Engineering

First Operations

Welding

Machining

Finishing

## IGM - Robotic Welding Machines





# OUR CAPABILITIES

Design & Engineering

First Operations

Welding

Machining

Finishing

## IGM - Robotic Welding Machines





# OUR CAPABILITIES

Design & Engineering

First Operations

**Welding**

Machining

Finishing

## 6 Axis Robotic Welding Machine







# OUR CAPABILITIES

Design & Engineering

First Operations

Welding

Machining

Finishing

## IGM - Robotic Welding & Komatsu Uranami Welding Machine ( UT Joint )





# OUR CAPABILITIES

Design & Engineering

First Operations

Welding

Machining

Finishing

## Sub Merged Arc Welding Machines



## 400 & 600 Amps MIG / MAG Welding

### Machines





# OUR CAPABILITIES

Design & Engineering

First Operations

Welding

Machining

Finishing

## Welding positioners for all types of Structures





# OUR CAPABILITIES

Design & Engineering

First Operations

**Welding**

Machining

Finishing

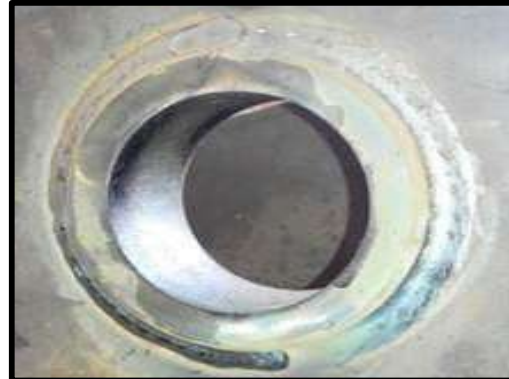



# OUR CAPABILITIES

Design & Engineering

First Operations

**Welding**

Machining

Finishing

## Welding Certifications:

- **ISO 3834-2 : 2021**  
( Welding Quality Management System )
- **EN 15085-2**  
(welding quality management systems )

## International Certified Welding Personnel at all Plants:

- **International Welding Specialists ( IWS )**
- **International Welding Engineers ( IWE )**
- **ISO 9712 - ASNT / NDT Level – II & Level – III Engineers.**





# OUR CAPABILITIES

Design & Engineering

First Operations

**Welding**

Machining

Finishing

**Non Destructive Tests being carried out at In-house by Certified Level II Engineers**

Ultrasonic Testing - UT



Magnetic Particle Testing - MPT



Liquid Penetrant Testing



Metallurgical Microscope



Hardness & Macro testing Lab



Pressure Leak Test





# OUR CAPABILITIES

Design & Engineering

First Operations

**Welding**

Machining

Finishing

## Welder Training School



## Consumable Samples



## Welding Defects



## Welding Positions





# OUR CAPABILITIES

Design & Engineering

First Operations

Welding

Machining

Finishing



## STRESS RELIEVING

### Typical Heat Treating Cycle

- Heating to the Control Temperature
- Holding at Temperature (Soak)
- Cooling (Rapid or at Slow / Controlled Rate)

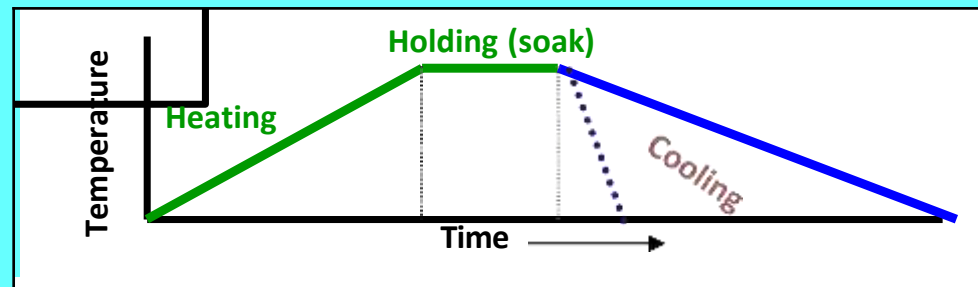

- ❖ Job Maximum Size:- 12X3.5X2.5 Mtr. <LXWXH>.
- ❖ Bogie Capacity:- 20 Ton.
- ❖ Operating Temperature:- 640°C.
- ❖ Type of Furnace:- Diesel Fire.
- ❖ No. Of Thermocouples:- 18 No's.
- ❖ Type of burner:- 8 No's High velocity Dual fuel burner.
- ❖ Heat cycle chart:- 18 points recorder with print out option.
- ❖ Process Control:- Fully Automatic.
- ❖ Temperature Control Concept:- The furnace temperature control concept is effected by means of a fully automatic control system through the 4 zones.







# OUR CAPABILITIES

Design & Engineering

First Operations

Welding

**Machining**

Finishing

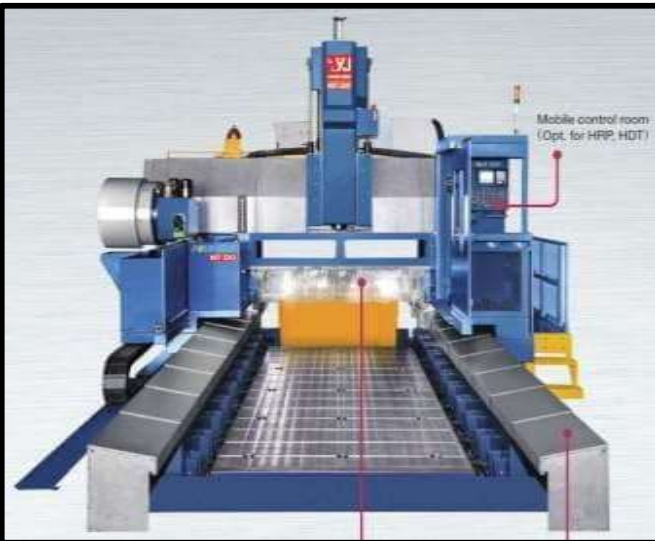

**Medium Travelling Double Column Machining Center**

Make : Four star , Taiwan

Machine Accuracy: 20Microns/1Mtr

X Axis Travel: 7000mm

Y Axis Travel: 2750mm

Z Axis Travel: 1500mm

ATC 24 Tools pallet

Auto Five Face head



**Fixed Double Column Machining Center**

Make : Four star , Taiwan

Machine Accuracy: 20Microns/1Mtr

X Axis Travel: 5000mm

Y Axis Travel: 3300mm

Z Axis Travel: 1500mm

ATC 32 Tools pallet

Spindle Power: 26/26 kW



**Vertical Machining Center**

Make : Four star , Taiwan

Machine Accuracy: 15Microns/ Full Travel

X Axis Travel: 3200mm

Y Axis Travel: 2100mm

Z Axis Travel: 650/1500mm

ATC 32 Tools Vertical arm type

Auto 90 degree head.



# OUR CAPABILITIES

Design & Engineering

First Operations

Welding

**Machining**

Finishing

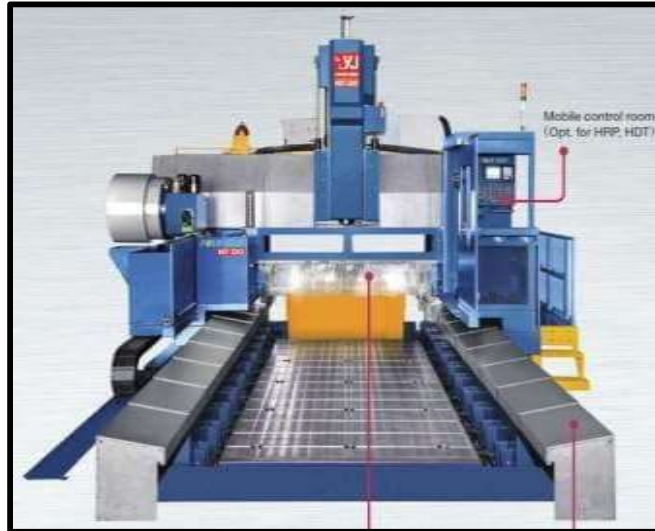
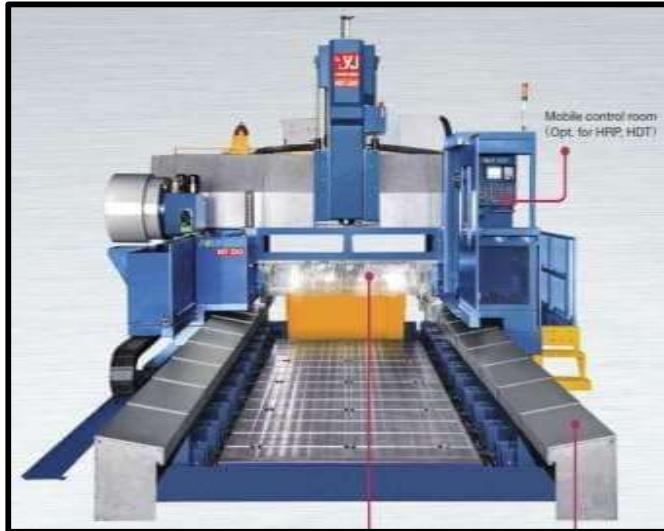

## Double Column Machining Centre (HDT 2470 + 5F)

Make : Four star , Taiwan

Machine Accuracy: 20Microns/1Mtr

X Axis Travel: 7000mm

Y Axis Travel: 2400+650mm

Z Axis Travel: 1500mm

ATC 24 Tools pallet

Auto Five Face head

## Double Column Machining Centre (HDT 2490 + 5F)

Make : Four star , Taiwan

Machine Accuracy: 20Microns/1Mtr

X Axis Travel: 9000mm

Y Axis Travel: 2400+650mm

Z Axis Travel: 1500mm

ATC 24 Tools pallet

Auto Five Face head

## Double Column Machining Centre (FD 3660 + 5F)

Make : Four star , Taiwan

Machine Accuracy: 20Microns/1Mtr

X Axis Travel: 6000mm

Y Axis Travel: 3600+650mm

Z Axis Travel: 1400mm

ATC 32 Tools pallet

Auto Five Face head



# OUR CAPABILITIES

Design & Engineering

First Operations

Welding

**Machining**

Finishing



## CNC Double Column Machine

Make : Forest Line, Italian

Machine Accuracy: 20Microns/1Mtr

X Axis Travel : 3100mm

Y Axis Travel : 3410mm

Z Axis Travel : 2000mm

W Axis Travel : 1500mm

Spindle Taper : BT50

Table Carrying Load : 20000 Kgs

## MDR-130 CNC Floor Boring Machine

Make: Juaristi

Machine Accuracy: 20Microns/1Mtr

X Axis Travel : 6600mm

Y Axis Travel : 2200mm

Z Axis Travel : 1200mm

W Axis Travel : 400mm

Spindle Diameter : 130mm

Table Carrying Load : 20000 Kgs

## CNC Horizontal Boring Machine

Make : Union BFT 130 (Heidenhain Controller)

Machine Accuracy: 20Microns/1Mtr

X Axis Travel : 2200mm

Y Axis Travel : 1700mm

Z Axis Travel : 2400mm

W Axis Travel : 770mm

Spindle Diameter : 130mm

Table Carrying Load : 10000 Kgs



# OUR CAPABILITIES

Design & Engineering

First Operations

Welding

**Machining**

Finishing



**CNC Juaristi TS-150 Floor Boring Machine**

Make: Juaristi

Machine Accuracy: 20Microns/1Mtr

X Axis Travel: 4000 mm

Y Axis Travel : 3000 mm

Z Axis Travel : 1000 mm

W Axis Travel: 2000 mm

Spindle Diameter: 130mm

Table Carrying Load : 20000 Kgs

**CNC T-Type Horizontal Boring Machine**

Make : Four star , Taiwan

Machine Accuracy: 20Microns/1Mtr

X Axis Travel: 3200mm

Y Axis Travel: 2000mm

Z Axis Travel: 1600mm

W Axis Travel: 700 mm (Quill Extension)

Spindle Diameter: 130mm

Table Carrying Load : 18000 Kgs

**Horizontal Boring Machine**

Make: Fermat

Machine Accuracy: 20Microns/1Mtr

X Axis Travel: 4000 mm

Y Axis Travel: 2000 mm

Z Axis Travel: 1600 mm

W Axis Spindle Travel: 730 mm

Spindle Diameter: 130mm

Table Carrying Load : 10000 Kgs



# OUR CAPABILITIES

Design & Engineering

First Operations

Welding

**Machining**

Finishing



## TOOL PRESETTER & MEASURING MACHINE

Make : ZOLER

Model: SMILE420X-00317

Maximum Tool Length Z = 600mm ( 23.62" )

Maximum Tool Diameter D = 420mm ( 16.54" )

Snap Gauge d = 100mm ( 3.94" )

High Precision Spindle ISO 50  
Concentricity 0.002mm (0.000079")  
4 X 90 Deg Spindle Indexing  
Integrated Calibration Spheres



# OUR CAPABILITIES

Design & Engineering

First Operations

Welding

Machining

Finishing

## COORDINATE MEASURING MACHINE



### Coordinate Measuring Machine

Make : FARO Portable CMM Quantum E

Size : 3.5mtr 7 Axis with arm

Probe size : 3mm & 6mm.

Software : CAM2 2019 Probing Edition



# OUR CAPABILITIES

Design & Engineering

First Operations

Welding

Machining

Finishing



## Shot Blasting Rooms for Welded Assemblies

Make : Mec Shot

Eff. Blasting Length : 6 Mtrs to 9 Mtrs

Eff. Blasting Width : 4 Mtrs

Eff. Blasting Height : 4 Mtrs



## Paint Booth & Oven

Type : Dry / Wet Type

Length : 6 Mtrs to 9 Mtrs

Width : 4 Mtrs

Height : 4 Mtrs

**Note: Available at all plants**



# KEY ENABLERS FOR OUR CAPABILITIES

## People

- 1500+ people across MIC plants - including design professionals; design, production and quality engineers and welding professionals qualified as per international standards like ASME Sec IX and DIN 278
- Ongoing training for all our workers in Arc Welding, MIG welding, Dressing Fabricated Components, Fundamentals of Engineering Drawing etc.
- Motivated and experienced employees the average tenure of workers at MIC is 8 years

## Procurement

- MIC is one of the largest consumers of steel in its business space
- Owing to our annual order quantities, both domestic and imported steel suppliers store inventory for us, ensuring uninterrupted supply
- Our relationships with large mills enable us to obtain steel rolled as per our order, ensuring consistent quality

## Processes

- MIC is an ISO 9001:2015, ISO 3834-2-2021, EN 15085-2, ISO 14001, ISO 45001-2018, 27001-2022, 50001-2018 certified company
- ESG disclosure & rating is under progress
- We have robust processes, controls and reporting in place that enable us to operate at optimal efficiency levels and minimize wastage
- We have a strong network of sub-contractors, machinists, yards and warehouses that enables us to quickly ramp up when required by customers

## Partnership

- From being a dedicated supplier to Telcon when we first set up in Dharwad, we have evolved into a trusted partner to several of the reputed names in the industry
- We have endeavoured to constantly enhance our capabilities through partnering with reputed names. Our collaborations are included KOMATSU, JCB, TATA HITACHI, HYUNDAI, KOBELCO, SANY, VOLVO, PUTZMEISTER, DYNAPAC, WIRTGEN, ATLAS COPCO, SIEMENS GAMESA, AJAX, TAFE, CNH, EPIROC, ALSTOM, ADELTE etc..







Model Infra Corporation Pvt. Ltd.

## CONTENTS

1. Who we are
2. Who we work with
3. What we do
4. **Products Profile**
5. Awards & Certifications





# PRODUCTS PROFILE

## MIC has immense experience in manufacturing of variety of Buckets for Construction Equipment

MIC is the largest manufacturer of wide variety of buckets for excavators in India. Leading names in Construction Equipment including Komatsu, JCB, TATA Hitachi, Hyundai, Kobelco, Sany, Volvo, CNH etc. are among MIC's esteemed customers.

### Different varieties of buckets manufactured by MIC

20 – 25 Tons class excavator  
general purpose bucket



30 – 35 Tons class excavator  
general purpose bucket



45 – 50 Tons class excavator  
general purpose bucket



Heavy duty iron ore bucket



Granite bucket



Low profile bucket





# PRODUCTS PROFILE

Different varieties of buckets and attachments manufactured by MIC

**210 Class Ripper Bucket**



**380 Class Ripper Bucket**



**2.2 Cu M Ripper Bucket**



**12 & 20 Ton Tilt Bucket**



**24" Sheaves**



**4 Tine Hydraulic Grapple**





# PRODUCTS PROFILE

Different varieties of buckets and attachments manufactured by MIC

**Clampshell Buckect**



**Quarry Bucket**



**2.65 Arm & Quarry Bucket**

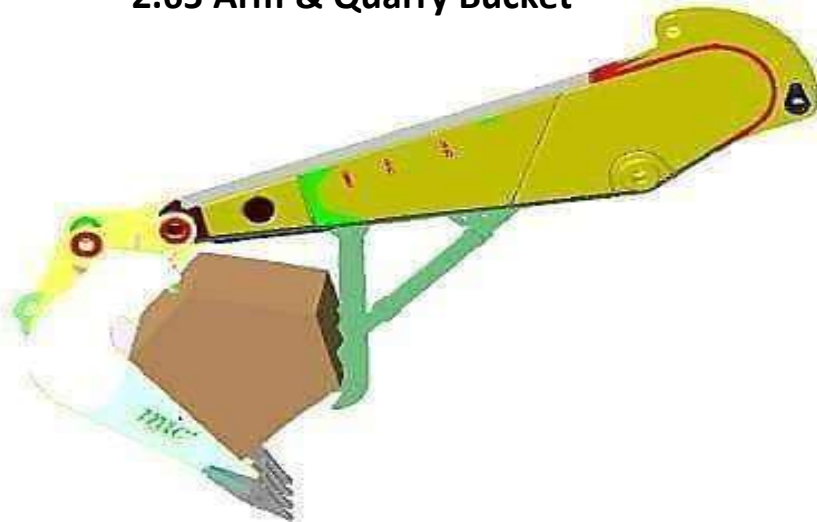

**Tilt Bucket**





# PRODUCTS PROFILE

Excavator thumbs designed and manufactured by MIC

**30 – 35 ton Machine EXCAVATOR THUMBS**



**Application : 1**



**Application : 2**





# PRODUCTS PROFILE

MIC manufactures many critical assemblies for Mining and Construction Equipment such as Arms , Booms and other complex body structures like Track Frames, Revolving Frames, Chassis, Platforms etc.,

**Booms**



**Arms**



**Center Frames**



**LH & RH Platforms**



**Track Frames**



**Chassis**





# PRODUCTS PROFILE

## Long Reach Arm & Boom





# PRODUCTS PROFILE

## Counter Weights Filling & Finishing

Counterweights are integral part of a variety of big machines dealing with huge load. By balancing the weight, they secure a safety performance of Excavators, Tractors, Forklift trucks, Cranes and others. The manufacturers prefer using either full cast iron, full concrete, or a mix of ore, concrete and metal bits.

### Excavator Counter weights



### Wheel Loader Counter weights







# PRODUCTS PROFILE

## Products for Road Industry & Crushers.

**Chassis for crushers**



**Chassis for Pavers**



**Frames for Compactors**





# PRODUCTS PROFILE

## Mobile Crusher Chassis



Platform for Mining Equipment



Impact Crushers





# PRODUCTS PROFILE

## Chassis and Hoppers for Concrete Mixers

Chassis

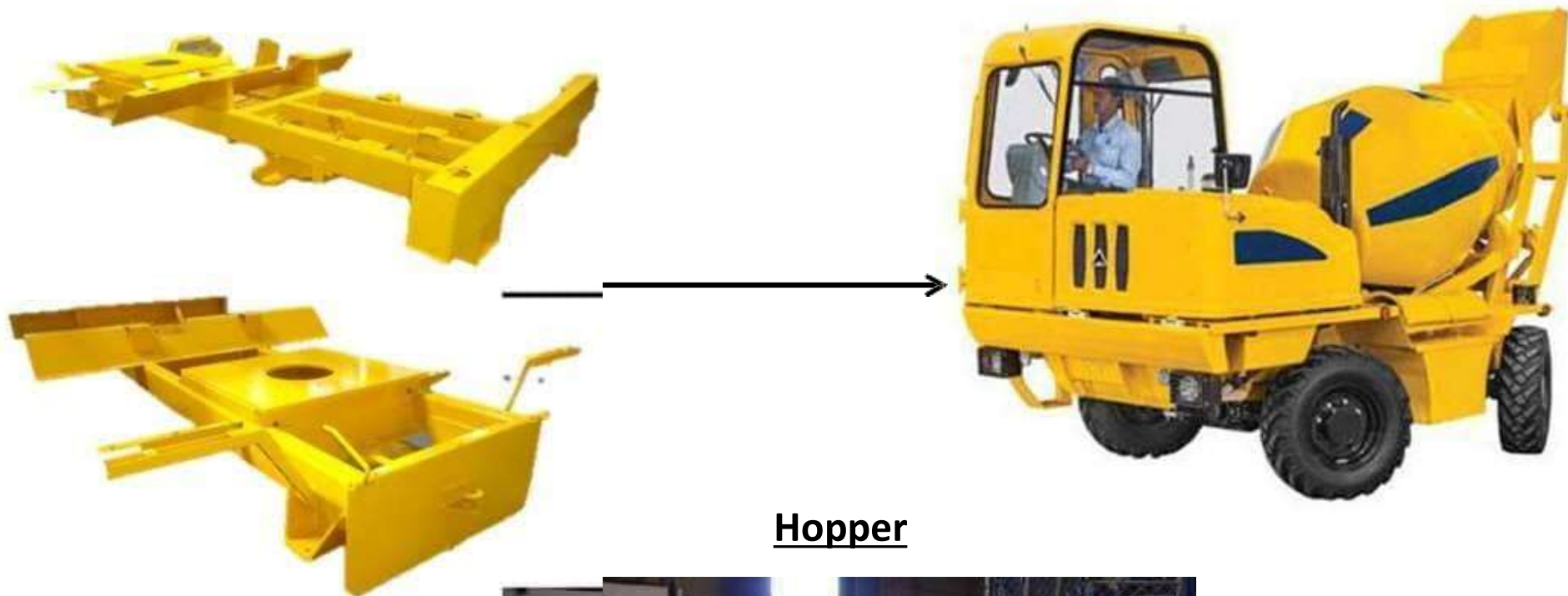

Hopper





# PRODUCTS PROFILE

## Fabricated Structures for Concrete Mixers

**Chassis**



**Mixer Drum**



**Loading Arm**

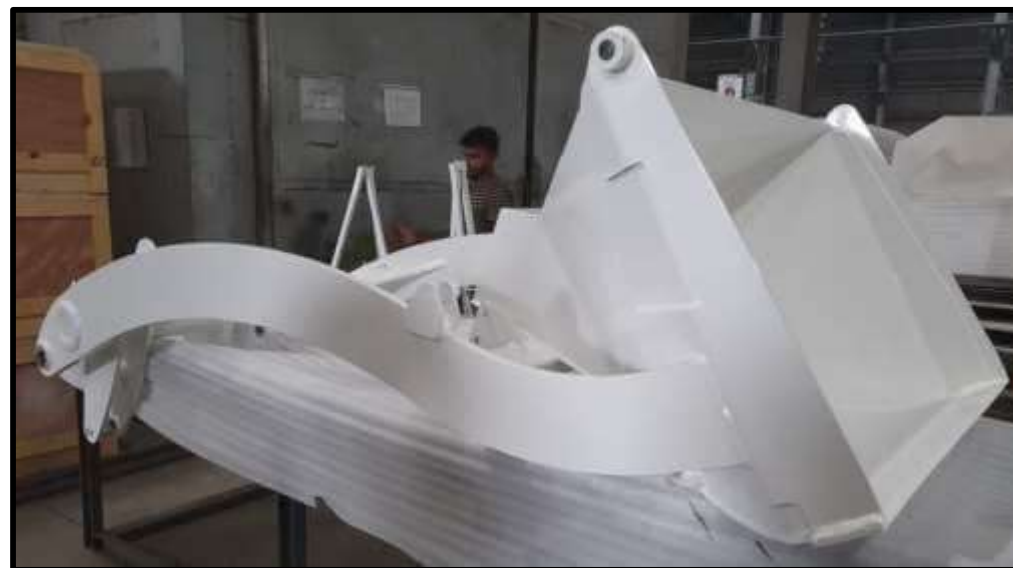



# PRODUCTS PROFILE

Products for Conventional and Renewable Energy Sectors.

**Stator Frames for AC Generators**



**Bell Housing**



**End Shields**



**Frames for Wind Mills**



**Terminal Boxes**





# PRODUCTS PROFILE

## Products for Railways

### ALSTOM TRANSPORTATION: ASSEMBLIES & PARTS FOR METRO RAIL (GLOBAL)

**Under Frames for Metro Rail**



**Cab Structure for Metro Rail**





# PRODUCTS PROFILE

## Products for Railways

### ALSTOM TRANSPORTATION: E-LOCO VENTILLATION STRUCTURE





# PRODUCTS PROFILE

## Products for Railways

ICF, BEML, SAN LOCO, INDIAN RAILWAYS

**Bogie Frame**



**Head Stock**



**Bogie Bolster**



**Body Bolster**







# PRODUCTS PROFILE

## Parts for Agriculture Sector

**Front Lift Arm**



**ROPS – Top Member Assembly**



**ROPS – Assembly bottom frame  
(LH & RH)**



**Drawbar Assembly**



**Front Hitch Assembly**



**Front Weight Frame**



**Assembly Draw Bar  
Bracket**





# PRODUCTS PROFILE

## Cabin & Rotunda for Aerobridges





# PRODUCTS PROFILE

## Equipment assembled for defense sector

**Illustration of Object Laying Machine assembled by MIC as per customer order**

**Fabricated components like, Under Frame, Rotating Base Body and Launch Beam Assembly for Rocket Launchers**

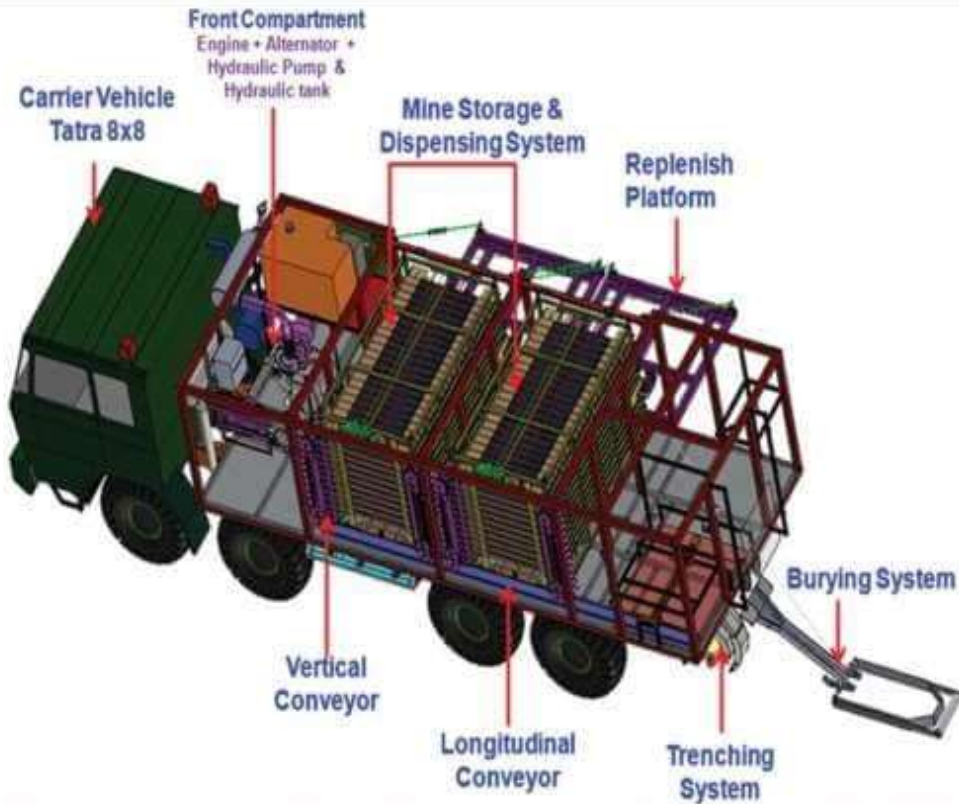



# PRODUCTS PROFILE

**MIC undertook the erection of a coke-oven plant in Goa for a client, as the principal partner in a partnership with VeCon of Germany (EPC)**

## Coke oven plant erection in Goa





Model Infra Corporation Pvt. Ltd.

## CONTENTS

1. Who we are
2. What we do
3. Who we work with
4. Products Profile
5. **Awards & Certifications**

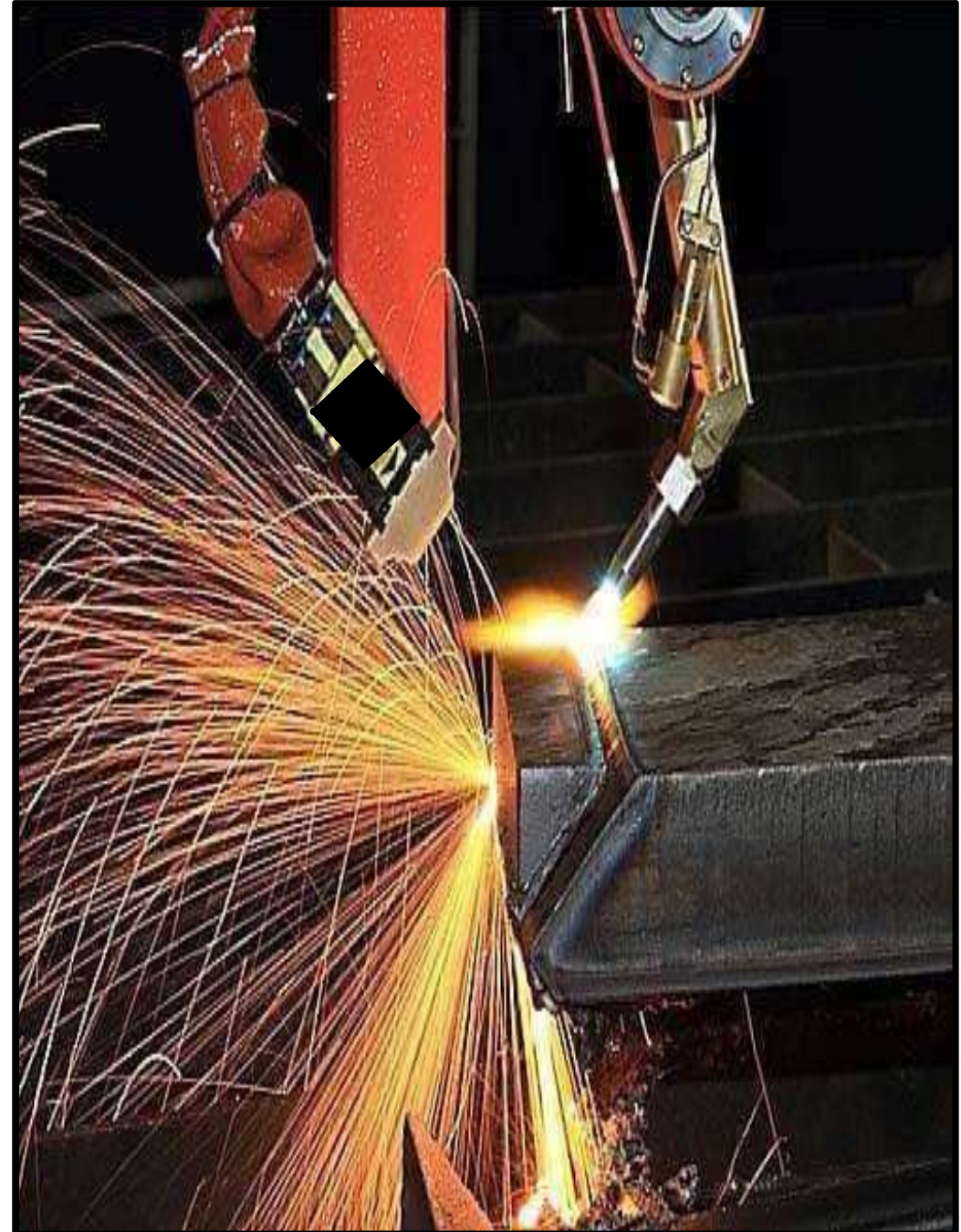



# AWARDS AND CERTIFICATIONS

	<p>Awarded for Significant Contribution - FY 24          Awarded for Best Delivery Performance - FY 22          Awarded for Best 5S - FY 21          Awarded for Plant Manager Award - FY 21          Awarded for Best Delivery &amp; Performance - FY 18</p>
	<p>Awarded for Q4'24 VOLUME RAMP UP - FY 24          Awarded for Best VA/VE Award - FY 22          Awarded for Over all Excellence Award from JCB - FY 17          Awarded for Top Significant Contributions recognition - FY 16          Awarded for Best Supplier for Delivery, Production Ramp-ups, Quick Responsiveness - FY 10</p>
	<p>Awarded for Best Performance In QCD Excellence - FY 22</p>
	<p>Awarded for Best Quality Performance – FY 19</p>
	<p>Awarded for Best Supplier Award for Joint Business Development by IBU - FY 19</p>
	<p>Awarded for Best Quality Performance - FY 18</p>
	<p>Awarded for After Market Support (Spare Parts) - Fy 22          Award of Excellence for Sustained Performance in Quality - FY 17</p>
	<p>Awarded for Best Supplier award from L&amp;T Komatsu in 2012 with a 95%+ delivery track record In last 24 months with sustained quality.</p>



# AWARDS AND CERTIFICATIONS





# AWARDS AND CERTIFICATIONS







# AWARDS AND CERTIFICATIONS





# AWARDS AND CERTIFICATIONS





# AWARDS AND CERTIFICATIONS





# AWARDS AND CERTIFICATIONS

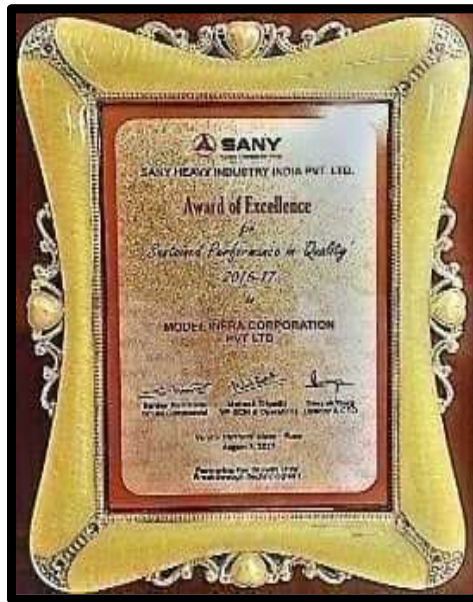



# AWARDS AND CERTIFICATIONS





# QMS : ISO 9001:2015 CERTIFICATES

**intertek**  
ISO 9001:2015

## CERTIFICATE OF REGISTRATION

This is to certify that the management system of:

**MIIC**

**Model Infra Corporation Pvt. Ltd.**

Main Site: Survey No. 224, Chembalapur Industrial Area, Midway Road/1st Main, Chembalapur, Bangalore - 562202, Karnataka, India.  
Site specific address: see appendix for more information.

has been registered by Intertek in conformity to the requirements of **ISO 9001:2015**

The management system is applicable to:  
Manufacture of components, Structures & Modules for Earth-moving equipment, Mining equipment, Concrete pumping equipment, Windmills, Agriculture equipment, Power plants, Railway vehicles and for other Engineering industries

**intertek**  
UKAS  
CERTIFICATION

**intertek**  
ISO 9001:2015

**intertek**  
ISO 9001:2015

**intertek**  
ISO 9001:2015

**intertek**  
ISO 9001:2015

**intertek**  
ISO 9001:2015

## APPENDIX TO CERTIFICATE OF REGISTRATION

### APPENDIX

This appendix identifies the locations by the management system of:

**Model Infra Corporation Pvt. Ltd.**

This appendix is linked to the Main Certificate # 0200222 and cannot be shown nor reproduced without it. The validity of this certificate depends on the validity of the main certificate.

**Model Infra Corporation Pvt. Ltd.**

Survey No. 24729, Thiruvir Mitha Road, Kambanahalli, Kambanahalli Tank, Kambanahalli District - 600092, Tamil Nadu, India.

Manufacture of components, Structures & Modules for Earth-moving equipment, Mining equipment, Concrete pumping equipment, Windmills, Agriculture equipment, Power plants, Railway vehicles and for other Engineering industries.

**intertek**  
ISO 9001:2015

**intertek**  
ISO 9001:2015

**intertek**  
ISO 9001:2015

## APPENDIX TO CERTIFICATE OF REGISTRATION

### APPENDIX

This appendix identifies the locations by the management system of:

**Model Infra Corporation Pvt. Ltd.**

This appendix is linked to the Main Certificate # 0200222 and cannot be shown nor reproduced without it. The validity of this certificate depends on the validity of the main certificate.

**Model Infra Corporation Pvt. Ltd.**

No. 204, Nello Iparru College Park, Kothakota-Impeyambar Road-Thiruvir Main Road, Thiruvir District - 600061, Tamil Nadu, India.

Manufacture of components, Structures & Modules for Earth-moving equipment, Mining equipment, Concrete pumping equipment, Windmills, Agriculture equipment, Power plants, Railway vehicles and for other Engineering industries.

**intertek**  
ISO 9001:2015

**intertek**  
ISO 9001:2015

**intertek**  
ISO 9001:2015

## APPENDIX TO CERTIFICATE OF REGISTRATION

### APPENDIX

This appendix identifies the locations by the management system of:

**Model Infra Corporation Pvt. Ltd.**

This appendix is linked to the Main Certificate # 0200222 and cannot be shown nor reproduced without it. The validity of this certificate depends on the validity of the main certificate.

**Model Infra Corporation Pvt. Ltd.**

4221, SHARU Industrial Growth Centre, India, Chennai - 600011, Karnataka, India.

Manufacture of components, Structures & Modules for Earth-moving equipment, Mining equipment, Concrete pumping equipment, Windmills, Agriculture equipment, Power plants, Railway vehicles and for other Engineering industries.

**intertek**  
ISO 9001:2015

**intertek**  
ISO 9001:2015

**intertek**  
ISO 9001:2015

## APPENDIX TO CERTIFICATE OF REGISTRATION

### APPENDIX

This appendix identifies the locations by the management system of:

**Model Infra Corporation Pvt. Ltd.**

This appendix is linked to the Main Certificate # 0200222 and cannot be shown nor reproduced without it. The validity of this certificate depends on the validity of the main certificate.

**Model Infra Corporation Pvt. Ltd.**

# 224 & 225, SHARU, Kolar Industrial Area, Chennai-600011, Karnataka, India.

Manufacture of components, Structures & Modules for Earth-moving equipment, Mining equipment, Concrete pumping equipment, Windmills, Agriculture equipment, Power plants, Railway vehicles and for other Engineering industries.

**intertek**  
ISO 9001:2015

**intertek**  
ISO 9001:2015

**intertek**  
ISO 9001:2015

## APPENDIX TO CERTIFICATE OF REGISTRATION

### APPENDIX

This appendix identifies the locations by the management system of:

**Model Infra Corporation Pvt. Ltd.**

This appendix is linked to the Main Certificate # 0200222 and cannot be shown nor reproduced without it. The validity of this certificate depends on the validity of the main certificate.

**Model Infra Corporation Pvt. Ltd.**

11-13, Vanni Industrial Estate, Nellore, India - 600122, India.

Manufacture of components, Structures & Modules for Earth-moving equipment, Mining equipment, Concrete pumping equipment, Windmills, Agriculture equipment, Power plants, Railway vehicles and for other Engineering industries.

**intertek**  
ISO 9001:2015

**intertek**  
ISO 9001:2015

**intertek**  
ISO 9001:2015

## APPENDIX TO CERTIFICATE OF REGISTRATION

### APPENDIX

This appendix identifies the locations by the management system of:

**Model Infra Corporation Pvt. Ltd.**

This appendix is linked to the Main Certificate # 0200222 and cannot be shown nor reproduced without it. The validity of this certificate depends on the validity of the main certificate.

**Model Infra Corporation Pvt. Ltd.**

Plot No. 43, Gata No. 67361, Bopal Industrial Area, Kambanahalli, Chennai, Tamil Nadu, India - 600062, Karnataka, India.

Manufacture of components, Structures & Modules for Earth-moving equipment, Mining equipment, Concrete pumping equipment, Windmills, Agriculture equipment, Power plants, Railway vehicles and for other Engineering industries.

**intertek**  
ISO 9001:2015

**intertek**  
ISO 9001:2015

**intertek**  
ISO 9001:2015

## APPENDIX TO CERTIFICATE OF REGISTRATION

### APPENDIX

This appendix identifies the locations by the management system of:

**Model Infra Corporation Pvt. Ltd.**

This appendix is linked to the Main Certificate # 0200222 and cannot be shown nor reproduced without it. The validity of this certificate depends on the validity of the main certificate.

**Model Infra Corporation Pvt. Ltd.**

Plot No. 22, Opp. To Shree Prasad Peppery, A.P. Subb, Kambanahalli, Tamil Nadu, India - 600011, Karnataka, India.

Manufacture of components, Structures & Modules for Earth-moving equipment, Mining equipment, Concrete pumping equipment, Windmills, Agriculture equipment, Power plants, Railway vehicles and for other Engineering industries.

**intertek**  
ISO 9001:2015

**intertek**  
ISO 9001:2015



# EMS : ISO 14001:2015 CERTIFICATES

**intertek**  
CERTIFICATE OF REGISTRATION

This is to certify that the management system of:

**Model Infra Corporation Pvt. Ltd.**

Manufacture of components, Structures & Modules for Earth moving equipment, Mining equipment, Concrete pumping equipment, Winchless, Agriculture equipment, Power plants, Railway vehicles and for other Engineering industries.

ISO 14001:2015

The management system is applicable to:

Manufacture of components, Structures & Modules for Earth moving equipment, Mining equipment, Concrete pumping equipment, Winchless, Agriculture equipment, Power plants, Railway vehicles and for other Engineering industries.

intertek  
UKAS



**intertek**  
APPENDIX TO CERTIFICATE OF REGISTRATION

**APPENDIX**

This appendix identifies the locations by the management system of:

**Model Infra Corporation Pvt. Ltd.**

This appendix is linked to the Main Certificate # 0133179 and cannot be shown or reproduced without it. The validity of this certificate depends on the validity of the main certificate.

Model Infra Corporation Pvt. Ltd.

Survey No. 23/22, Trowar Man Road, Indarjaya, Kabupaten Tana Toraja, Sulawesi Selatan - 92000, Tana Toraja, India.

Manufacture of components, Structures & Modules for Earth moving equipment, Mining equipment, Concrete pumping equipment, Winchless, Agriculture equipment, Power plants, Railway vehicles and for other Engineering industries.



**intertek**  
APPENDIX TO CERTIFICATE OF REGISTRATION

**APPENDIX**

This appendix identifies the locations by the management system of:

**Model Infra Corporation Pvt. Ltd.**

This appendix is linked to the Main Certificate # 0133179 and cannot be shown or reproduced without it. The validity of this certificate depends on the validity of the main certificate.

Model Infra Corporation Pvt. Ltd.

No. 24, Indo Sate Logistik Park, Kawasan Industri Terusan-Terusan Man Road, Trowar District - 92000, Tana Toraja, India.

Manufacture of components, Structures & Modules for Earth moving equipment, Mining equipment, Concrete pumping equipment, Winchless, Agriculture equipment, Power plants, Railway vehicles and for other Engineering industries.



**intertek**  
APPENDIX TO CERTIFICATE OF REGISTRATION

**APPENDIX**

This appendix identifies the locations by the management system of:

**Model Infra Corporation Pvt. Ltd.**

This appendix is linked to the Main Certificate # 0133179 and cannot be shown or reproduced without it. The validity of this certificate depends on the validity of the main certificate.

Model Infra Corporation Pvt. Ltd.

KEL. KAN Industrial Growth Centre, Batu, Okrang - 80001, Sumatera, India.

Manufacture of components, Structures & Modules for Earth moving equipment, Mining equipment, Concrete pumping equipment, Winchless, Agriculture equipment, Power plants, Railway vehicles and for other Engineering industries.



**intertek**  
APPENDIX TO CERTIFICATE OF REGISTRATION

**APPENDIX**

This appendix identifies the locations by the management system of:

**Model Infra Corporation Pvt. Ltd.**

This appendix is linked to the Main Certificate # 0133179 and cannot be shown or reproduced without it. The validity of this certificate depends on the validity of the main certificate.

Model Infra Corporation Pvt. Ltd.

# 22-B-22, KH06, Banjar Industrial area, Okrang-80001, Sumatera, India.

Manufacture of components, Structures & Modules for Earth moving equipment, Mining equipment, Concrete pumping equipment, Winchless, Agriculture equipment, Power plants, Railway vehicles and for other Engineering industries.



**intertek**  
APPENDIX TO CERTIFICATE OF REGISTRATION

**APPENDIX**

This appendix identifies the locations by the management system of:

**Model Infra Corporation Pvt. Ltd.**

This appendix is linked to the Main Certificate # 0133179 and cannot be shown or reproduced without it. The validity of this certificate depends on the validity of the main certificate.

Model Infra Corporation Pvt. Ltd.

I-11, Viena Industrial Estate, Viena, Gasa - 90721, India.

Manufacture of components, Structures & Modules for Earth moving equipment, Mining equipment, Concrete pumping equipment, Winchless, Agriculture equipment, Power plants, Railway vehicles and for other Engineering industries.



**intertek**  
APPENDIX TO CERTIFICATE OF REGISTRATION

**APPENDIX**

This appendix identifies the locations by the management system of:

**Model Infra Corporation Pvt. Ltd.**

This appendix is linked to the Main Certificate # 0133179 and cannot be shown or reproduced without it. The validity of this certificate depends on the validity of the main certificate.

Model Infra Corporation Pvt. Ltd.

Plot No.22, Gasa Industrial Area, Kandi Village, Okrang, Tana Toraja - 92001, Sulawesi Selatan, India.

Manufacture of components, Structures & Modules for Earth moving equipment, Mining equipment, Concrete pumping equipment, Winchless, Agriculture equipment, Power plants, Railway vehicles and for other Engineering industries.



**intertek**  
APPENDIX TO CERTIFICATE OF REGISTRATION

**APPENDIX**

This appendix identifies the locations by the management system of:

**Model Infra Corporation Pvt. Ltd.**

This appendix is linked to the Main Certificate # 0133179 and cannot be shown or reproduced without it. The validity of this certificate depends on the validity of the main certificate.

Model Infra Corporation Pvt. Ltd.

Site No.22, Gasa Industrial Area, Kandi Village, Okrang, Tana Toraja - 92001, Sulawesi Selatan, India.

Manufacture of components, Structures & Modules for Earth moving equipment, Mining equipment, Concrete pumping equipment, Winchless, Agriculture equipment, Power plants, Railway vehicles and for other Engineering industries.





# OHSAS : ISO 45001: 2018 CERTIFICATES

**intertek**  
The Quality Source

## CERTIFICATE OF REGISTRATION

This is to verify that the management system of

**Model Infra Corporation Pvt. Ltd.**

Manufacture of components, Structures & Modules for Earth moving equipment, Mining equipment, Concrete pumping equipment, Windmills, Agriculture equipment, Power plants, Railway vehicles and for other Engineering industries.

**ISO 45001:2018**

The management system is applicable for:

Manufacture of components, Structures & Modules for Earth moving equipment, Mining equipment, Concrete pumping equipment, Windmills, Agriculture equipment, Power plants, Railway vehicles and for other Engineering industries.

**intertek**  
UKAS

UKAS  
1135

Intertek Certification Limited  
88 Victoria Road  
Teddington TW20 8DZ, United Kingdom

Intertek Certification Limited is a ISO2 certified body under the jurisdiction of UKAS.



**intertek**  
The Quality Source

## APPENDIX TO CERTIFICATE OF REGISTRATION

### APPENDIX

This appendix identifies the locations by the management system of

### Model Infra Corporation Pvt. Ltd.

This appendix is linked to the Main Certificate # 2152322 and cannot be shown nor reproduced without it. The validity of this certificate depends on the validity of the main certificate.

**Model Infra Corporation Pvt. Ltd.**

Survey No. 1178, Trivelloor Main Road, Karamanagalkott, Dargamohalla Taluk, Kanyakumari District - 620002, Tamil Nadu, India.

Manufacture of components, Structures & Modules for Earth moving equipment, Mining equipment, Concrete pumping equipment, Windmills, Agriculture equipment, Power plants, Railway vehicles and for other Engineering industries.



**intertek**  
The Quality Source

## APPENDIX TO CERTIFICATE OF REGISTRATION

### APPENDIX

This appendix identifies the locations by the management system of

### Model Infra Corporation Pvt. Ltd.

This appendix is linked to the Main Certificate # 2152322 and cannot be shown nor reproduced without it. The validity of this certificate depends on the validity of the main certificate.

**Model Infra Corporation Pvt. Ltd.**

Plot 204, Sree Sagar Logistics Park, Perinthalam Dargamohalla - Trivelloor Main Road, Trivelloor District - 620002, Tamil Nadu, India.

Manufacture of components, Structures & Modules for Earth moving equipment, Mining equipment, Concrete pumping equipment, Windmills, Agriculture equipment, Power plants, Railway vehicles and for other Engineering industries.



**intertek**  
The Quality Source

## APPENDIX TO CERTIFICATE OF REGISTRATION

### APPENDIX

This appendix identifies the locations by the management system of

### Model Infra Corporation Pvt. Ltd.

This appendix is linked to the Main Certificate # 2152322 and cannot be shown nor reproduced without it. The validity of this certificate depends on the validity of the main certificate.

**Model Infra Corporation Pvt. Ltd.**

Plot 11, KADE Industrial Growth Centre, Sree, Chinnai-680011, Karnataka, India.

Manufacture of components, Structures & Modules for Earth moving equipment, Mining equipment, Concrete pumping equipment, Windmills, Agriculture equipment, Power plants, Railway vehicles and for other Engineering industries.



**intertek**  
The Quality Source

## APPENDIX TO CERTIFICATE OF REGISTRATION

### APPENDIX

This appendix identifies the locations by the management system of

### Model Infra Corporation Pvt. Ltd.

This appendix is linked to the Main Certificate # 2152322 and cannot be shown nor reproduced without it. The validity of this certificate depends on the validity of the main certificate.

**Model Infra Corporation Pvt. Ltd.**

# 228-K-228, HADE Industrial Area, Chinnai-680011, Karnataka, India.

Manufacture of components, Structures & Modules for Earth moving equipment, Mining equipment, Concrete pumping equipment, Windmills, Agriculture equipment, Power plants, Railway vehicles and for other Engineering industries.



**intertek**  
The Quality Source

## APPENDIX TO CERTIFICATE OF REGISTRATION

### APPENDIX

This appendix identifies the locations by the management system of

### Model Infra Corporation Pvt. Ltd.

This appendix is linked to the Main Certificate # 2152322 and cannot be shown nor reproduced without it. The validity of this certificate depends on the validity of the main certificate.

**Model Infra Corporation Pvt. Ltd.**

L-54, Venu Industrial Estate, Sree, Sree - 482721, India.

Manufacture of components, Structures & Modules for Earth moving equipment, Mining equipment, Concrete pumping equipment, Windmills, Agriculture equipment, Power plants, Railway vehicles and for other Engineering industries.



**intertek**  
The Quality Source

## APPENDIX TO CERTIFICATE OF REGISTRATION

### APPENDIX

This appendix identifies the locations by the management system of

### Model Infra Corporation Pvt. Ltd.

This appendix is linked to the Main Certificate # 2152322 and cannot be shown nor reproduced without it. The validity of this certificate depends on the validity of the main certificate.

**Model Infra Corporation Pvt. Ltd.**

Plot No. 11, Sree No 479/D, Sree Industrial Area, Sree Village, Chinnai, Tamil Nadu, Pin-620002, Madhavaram, India.

Manufacture of components, Structures & Modules for Earth moving equipment, Mining equipment, Concrete pumping equipment, Windmills, Agriculture equipment, Power plants, Railway vehicles and for other Engineering industries.



**intertek**  
The Quality Source

## APPENDIX TO CERTIFICATE OF REGISTRATION

### APPENDIX

This appendix identifies the locations by the management system of

### Model Infra Corporation Pvt. Ltd.

This appendix is linked to the Main Certificate # 2152322 and cannot be shown nor reproduced without it. The validity of this certificate depends on the validity of the main certificate.

**Model Infra Corporation Pvt. Ltd.**

Plot No. 28, Opp. To Water Power Pump, A/P Sree, Sree, Sree - 620002, Sree - 620002, Madhavaram, India.

Manufacture of components, Structures & Modules for Earth moving equipment, Mining equipment, Concrete pumping equipment, Windmills, Agriculture equipment, Power plants, Railway vehicles and for other Engineering industries.







# WELDING : ISO 3834 : 2021 CERTIFICATES

**intertek**  
Test Data System

**CERTIFICATE OF REGISTRATION**

This is to certify that the Quality Management System for Welding of  
**Model Infra Corporation Pvt.Ltd**

Model Infra Corporation Pvt.Ltd  
 Plot No. Survey No. 506, Doddaballapur Industrial Area,  
 Mysuru Industrial Estate, Doddaballapur, Bangalore - 562202, Karnataka, India  
 has been assessed by Intertek as conforming to the requirements of:

**ISO 3834-2: 2021**

QUALITY REQUIREMENTS FOR STEEL WELDING OF METALS IN INDUSTRIAL, COMMERCIAL QUALITY REQUIREMENTS.

The Welding Quality Management System is applicable to the manufacture of Components and Fittings for steel piping equipment, piping equipment, steam power piping equipment, steel mills, agricultural equipment, general structural steel, and piping (pressure grade 1, 2, 3 and 4) in 200 MPa steel, 250 MPa, 300 MPa and 355 MPa steels.

The validity of this certificate depends on the validity of the term certificate # 12345678.

**intertek** **ACCREDITED** **intertek**

**Edin Mathewson**  
 President, Business Development  
 10000 Valley Road  
 Fort Worth, TX 76150  
 20251 Commerce of Fort Worth, TX 76150

**intertek**  
Test Data System

**APPENDIX TO CERTIFICATE OF REGISTRATION**

This appendix identifies the locations covered by the management system of  
**Model Infra Corporation Pvt.Ltd**

This appendix is limited to the locations # 12345678 and does not extend to other locations not specified below.

Model Infra Corporation Pvt. Ltd  
 Plot No. Survey No. 506, Doddaballapur Industrial Area, Mysuru Industrial Estate,  
 Doddaballapur, Bangalore - 562202, Karnataka, India  
 Manufacture of Components and Fittings for steel piping equipment, piping equipment, steam power piping equipment, steel mills, agricultural equipment, general structural steel, and piping (pressure grade 1, 2, 3 and 4) in 200 MPa steel, 250 MPa, 300 MPa and 355 MPa steels.

Model Infra Corporation Pvt. Ltd  
 Plot No. Survey No. 506, Doddaballapur Industrial Area, Mysuru Industrial Estate,  
 Doddaballapur, Bangalore - 562202, Karnataka, India  
 Manufacture of Components and Fittings for steel piping equipment, piping equipment, steam power piping equipment, steel mills, agricultural equipment, general structural steel, and piping (pressure grade 1, 2, 3 and 4) in 200 MPa steel, 250 MPa, 300 MPa and 355 MPa steels.

The validity of this appendix depends on the validity of the term certificate # 12345678.

**intertek** **ACCREDITED** **intertek**

**Edin Mathewson**  
 President, Business Development  
 10000 Valley Road  
 Fort Worth, TX 76150  
 20251 Commerce of Fort Worth, TX 76150

**intertek**  
Test Data System

**APPENDIX TO CERTIFICATE OF REGISTRATION**

This appendix identifies the locations covered by the management system of  
**Model Infra Corporation Pvt.Ltd**

This appendix is limited to the locations # 12345678 and does not extend to other locations not specified below.

Model Infra Corporation Pvt. Ltd  
 Plot No. Survey No. 506, Doddaballapur Industrial Area, Mysuru Industrial Estate,  
 Doddaballapur, Bangalore - 562202, Karnataka, India  
 Manufacture of Components and Fittings for steel piping equipment, piping equipment, steam power piping equipment, steel mills, agricultural equipment, general structural steel, and piping (pressure grade 1, 2, 3 and 4) in 200 MPa steel, 250 MPa, 300 MPa and 355 MPa steels.

Model Infra Corporation Pvt. Ltd  
 Plot No. Survey No. 506, Doddaballapur Industrial Area, Mysuru Industrial Estate,  
 Doddaballapur, Bangalore - 562202, Karnataka, India  
 Manufacture of Components and Fittings for steel piping equipment, piping equipment, steam power piping equipment, steel mills, agricultural equipment, general structural steel, and piping (pressure grade 1, 2, 3 and 4) in 200 MPa steel, 250 MPa, 300 MPa and 355 MPa steels.

The validity of this appendix depends on the validity of the term certificate # 12345678.

**intertek** **ACCREDITED** **intertek**

**Edin Mathewson**  
 President, Business Development  
 10000 Valley Road  
 Fort Worth, TX 76150  
 20251 Commerce of Fort Worth, TX 76150

**intertek**  
Test Data System

**APPENDIX TO CERTIFICATE OF REGISTRATION**

This appendix identifies the locations covered by the management system of  
**Model Infra Corporation Pvt.Ltd**

This appendix is limited to the locations # 12345678 and does not extend to other locations not specified below.

Model Infra Corporation Pvt. Ltd  
 Plot No. Survey No. 506, Doddaballapur Industrial Area, Mysuru Industrial Estate,  
 Doddaballapur, Bangalore - 562202, Karnataka, India  
 Manufacture of Components and Fittings for steel piping equipment, piping equipment, steam power piping equipment, steel mills, agricultural equipment, general structural steel, and piping (pressure grade 1, 2, 3 and 4) in 200 MPa steel, 250 MPa, 300 MPa and 355 MPa steels.

Model Infra Corporation Pvt. Ltd  
 Plot No. Survey No. 506, Doddaballapur Industrial Area, Mysuru Industrial Estate,  
 Doddaballapur, Bangalore - 562202, Karnataka, India  
 Manufacture of Components and Fittings for steel piping equipment, piping equipment, steam power piping equipment, steel mills, agricultural equipment, general structural steel, and piping (pressure grade 1, 2, 3 and 4) in 200 MPa steel, 250 MPa, 300 MPa and 355 MPa steels.

The validity of this appendix depends on the validity of the term certificate # 12345678.

**intertek** **ACCREDITED** **intertek**

**Edin Mathewson**  
 President, Business Development  
 10000 Valley Road  
 Fort Worth, TX 76150  
 20251 Commerce of Fort Worth, TX 76150

## WELDING : ISO 15085-2 CERTIFICATE

**CERTIFICATE**

Welding of railway vehicles and components according to EN 15085-2

TÜV RHEINLAND CERTIFICATE # 12345678

TÜV Rheinland Industrie Service GmbH hereby certifies that the welding company

**Model Infra Corporation Ltd**  
 Survey No: 15/28, #104 (Unit 1,2)  
 Sriperambudur - Tiruvallur Road, Kamlamangalam,  
 Indospace Logistics park - Polurakkam Village,  
 602002 Chennai, Tamilnadu  
 India

fulfills the requirements for this scope according to

**EN 15085-2 classification level CL1**  
 in the type of activity P  
 in the range indicated in this annex,  
 validity: 2023-09-08 until 2025-04-17

Intertek, 2023-09-08  
 Form 010-010-010  
 10000 Valley Road, Fort Worth, TX 76150

TÜV Rheinland Industrie Service GmbH, Am Rhein 100, 51109 Köln, Germany

**intertek** **ACCREDITED** **intertek**

**Edin Mathewson**  
 President, Business Development  
 10000 Valley Road  
 Fort Worth, TX 76150  
 20251 Commerce of Fort Worth, TX 76150



# ISMS : ISO 27001 : 2022 CERTIFICATE

**intertek**  
Total Quality Assurance

## CERTIFICATE OF REGISTRATION

This is to certify that the management system of:

### Model Infra Corporation Pvt. Ltd

Main Site: #06, 5th Floor, 2nd Floor, Sector A, 1st A Main Road, Rajahmundry New Town, Bangalore, Karnataka, 560064, India  
has been registered by Intertek as conforming to the requirements of:

### ISO/IEC 27001:2022

The management system is applicable to:

Provision of IT services to internal operations like Procurement, Quality, Finance & Accounts, Sales, Human Resources & Training, Administration, Coding and Product Development in accordance with the Statement of Applicability V1.0 dated 01/04/24.

Certificate Number: 0199004  
Initial Certification Date: 03 November 2024  
Date of Certification Decision: 03 November 2024  
Issuing Date: 03 November 2024  
Valid Until: 02 November 2027

   
Intertek  
  
Colin Moldovean  
President, Business Assurance

Intertek Certification Limited, 355 Victory Park, Victory Road, Derby DE24 027, United Kingdom  
Intertek Certification Limited is a UKAS accredited body under contract of accreditation no. 044 

In the absence of this certificate, Intertek does not apply its accreditation to the Client, and therefore is not responsible for the Client's compliance with the applicable certification requirements. This certificate is valid only in respect to the registration. Intertek is not liable for any claims arising from the use of this certificate. The certificate remains the property of Intertek. For more information, please contact us at [certificates@intertek.com](mailto:certificates@intertek.com) or by contacting the office in the right with a starburst icon. The certificate remains the property of Intertek. © Intertek Inc. All rights reserved.

Page 1 of 1





# CONTACT US

## MIC Units

### **Bangalore Plant**

**Model Infra Corporation Pvt. Ltd.,**  
104, Doddaballapur Industrial Area,  
Majara Hosahalli Hobli,  
Doddaballapur, Bangalore - 561 203  
Karnataka

Ph: + 91 080 43340300, Mobile: +91 7259437245

### **Goa Plant**

**Model Infra Corporation Pvt. Ltd.,**  
L-13, Verna Industrial Estate,  
Verna - 561 203,  
Goa

Ph: + 91 832 669 0981-84, Mobile: +91 9975445679

### **Pune Alandi Plant**

**Model Infra Corporation Pvt. Ltd.,**  
Survey No.34, A/P Solu, Alandi,  
Tal-Khed, Dist-Pune-410501  
Maharashtra.

Mobile: + 91 7774039522

### **Pune Chakkan Plant**

**Model Infra Corporation Pvt. Ltd.,**  
lot No.10, Gate No.679/2, Balaji Industrial Area,  
At/post-Kuruli Chakan, Tal-Khed, Dist-Pune-410501  
Maharashtra.

Mobile: + 91 7774039522

### **Dharwad Plant 1**

**Model Infra Corporation Pvt. Ltd.,**  
221, KIADB Industrial Growth Center,  
Belur, Dharwad - 580 011  
Karnataka

Ph: + 91 836 248 6785, Mobile: + 91 9945671129

### **Dharwad Plant 2**

**Model Infra Corporation Pvt. Ltd.,**  
Plat No 225 & 226, Sy No 100, 102, 8, 113 and 147,  
Belur Industrial Area, Mummigatti Hobli, Garag Taluk,  
Dharwad-580011, Karnataka

Mobile: + 91 9975445679

### **Chennai Polivakkam Plant**

**Model Infra Corporation Pvt. Ltd.,**  
#104, Indo Space Logistics Park, Polivakkam Village,  
Sriperambadur, Thiruvallur Main Road,  
Thiruvallur District , Tamil Nadu - 602002

Mobile : +91 9840607630

### **Chennai Kandamangalam Plant**

**Model Infra Corporation Pvt. Ltd.,**  
Survey No 15/2B, At Kandamangalam, Sriperambadur  
Taluk, Kancheepuram District - 602105  
Tamilnadu

Mobile : +91 9840607630



## CONTACT US

### Registered Office

No 6, 2<sup>nd</sup> floor, SMK Chambers,  
1st 'A' Main Road Sector A,  
Yelahanka New Town  
Bangalore 560 064  
Karnataka  
India.

Mobile: +91 8956958105

Mobile: +91 7259366972

E mail: [info@modelinfra.com](mailto:info@modelinfra.com)

Website: [www.modelinfra.com](http://www.modelinfra.com)

Disclaimer: This document is intended solely for informational purposes and may contain legally privileged and/or confidential information. Any unauthorized use or disclosure may be unlawful. All brand and product names and associated logos contained within this document belong to their respective owners and are protected by copyright. Under no circumstance may any of these be reproduced in any form without the prior written agreement of their owner. While every effort has been made to ensure accuracy, the information within this document is provided without warranty, and MIC shall not be liable for any errors contained herein, or damages of any type in connection with the use of this material



**MODEL INFRA CORPORATION PVT. LTD**

**THANK YOU**